

Specifications

MODEL		GTH-4017	
MEASUREMENTS		Metric	Imperial
Lifting height (maximum)		16.73 m	54 ft 11 in
Lifting capacity (maximum)		4,000 kg	8,818 lbs
Lift capacity at maximum height		2,500 kg	5,511 lbs
Lift capacity at maximum reach		700 kg	1,543 lbs
Forward reach (maximum)		12.44 m	40 ft 10 in
Reach at maximum height		1.28 m	4 ft 2 in
A Height		2.56 m	8 ft 5 in
B Height at steering wheel		1.98 m	6 ft 6 in
C Width		2.38 m	7 ft 10 in
D Inside cab width		91 cm	3 ft
E Track		1.98 m	6 ft 6 in
F Wheelbase		2.85 m	9 ft 4 in
G Length at stabilisers		4.52 m	14 ft 10 in
H Length at fork-holder plate		6.31 m	20 ft 8 in
I Ground clearance		46 cm	1 ft 6 in
L Overall width, stabilisers extended		2.93 m	9 ft 7 in
M1 Obstruction angle		39°	39°
M2 Departure angle		27°	27°

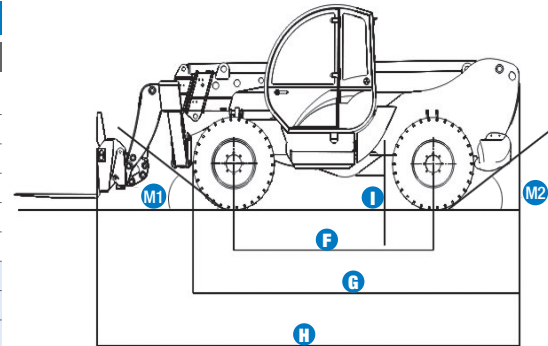

PRODUCTIVITY		
Lifting/lowering speed	12 sec./8 sec.	12 sec./8 sec.
Extension/retraction speed	16 sec./15 sec.	16 sec./15 sec.
Inside/outside turning radius	1.3 m/3.99 m	4 ft 3 in/13 ft 2 in
Break out force	7,400 kg	16,312 lbs
(with 500L shovel SAE J 732/80)		
Towing capacity at dynamometer	7,490 kg	16,511 lbs
Travel speed	35 km/h	22 mph
Fork-holder plate rotation	145°	145°
Chassis levelling on the front axle	+/- 8°	+/- 8°
Floating forks	L 1200 mm Section 120 x 50 mm	L 3 ft 11 in Section 5 in x 2 in
Tyres (DIN 70361)	405/70-24" PR14 8 holes wheel disc	

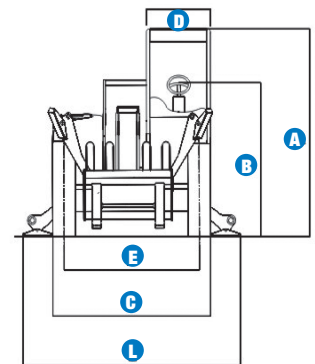

POWER		
Engine	Perkins Turbo Diesel 74.4 kW (101 HP)	
Tank capacities		
Fuel	135 L	30 gal
Engine oil	11.5 L	2 gal
Hydraulic oil	220 L	48 gal
Hydraulic output/pressure	95 L/min-270 bar	30 gal/min-3,916 psi

WEIGHT		
Weight*	11,900 kg	23,587 lbs

STANDARDS COMPLIANCE Operating cab conforms to ISO3471 (ROPS) and ISO3449 (FOPS)
Low emission engine conforms to UE 97/68 directives.

* Weight will vary depending on options and/or country standards

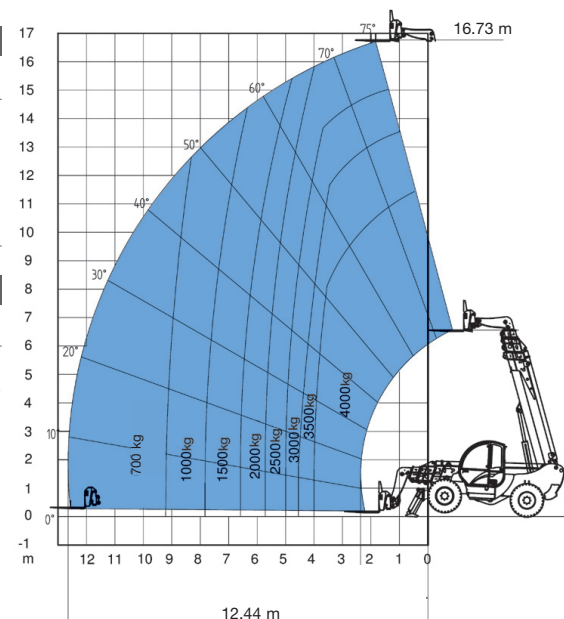

Lift capacity chart (with stabilisers)

EN1459, Annex B

Features

STANDARD FEATURES

MEASUREMENTS

- 4,000 kg (8,818 lbs) maximum lift capacity
- 16.73 m (54 ft 11 in) maximum lift height
- 12.44 m (40 ft 10 in) maximum forward reach

PRODUCTIVITY

- Four-wheel drive
- 3 steering modes:
 - front wheel steer
 - crab steer
 - coordinated steer
- Power assisted steering
- Front hydraulic stabilisers
- Two-speed mechanical gearbox
- Multifunction electric proportional joystick
- Limited slip differential on front axle
- Fork-holder plate and floating forks
- Chassis levelling
- Rear axle automatic lockout
- Quick coupling for attachments
- Adjustable suspended seat
- Large diameter steering wheel
- Front windscreen wipers
- Front & rear lights
- Oil immersed, multi-disc, self-adjusting brakes on both axles
- Lockable fuel tank
- Longitudinal stability control system with load monitor
- Visible display with coloured LEDs
- Audible alarm
- Automatic lock-out of boom extension and lowering
- Lockout of stabilisers and chassis levelling with boom raised
- Control enable switch

POWER

- Perkins Turbo Diesel 74.4 kW (101 HP)

TYRES

- 405/70-24" PR14 8 holes wheel disc



OPTIONS & ACCESSORIES

PRODUCTIVITY

- Electric pre-arrangement on boom
- Pre-arrangement for man-platform
- Emergency electric pump
- Pre-arrangement for mixing bucket
- Air conditioning
- Second hydraulic line on boom
- Special air filter
- Windshield protection grid
- Adjustable spotlight
- Wiper on cab roof
- Water muffler
- Complete radio remote control

ATTACHMENT OPTIONS

- Loading shovel 800 L
- Concrete bucket 500/800 L manual/hydraulic discharge
- Concrete mixing bucket 500 L with remote control
- Hydraulic jack 10 ton + box wrench 24 mm
- Brick-holder basket
- Fork side-shift (+/- 100 mm)
- Fixed hook on plate
- 4 m jib, 900 kg capacity
- 4 m jib with 900 kg capacity hydraulic winch
- Hydraulic winch 3000 kg
- Centring-holder boom (tunneling application)
- Fixed and rotating man-platform up to 4.64 m

TYRES

- Foam-filled tyres
- Spare wheel 405/70-24" PR14

European Offices

UK

The Maltings
Wharf Road
Grantham NG31 6BH
UK
Tel: +44 (0)1476 584333
Fax: +44 (0)1476 584334

France

10, ZA de la Croix St. Mathieu
28320 Gallardon
France
Tel: +33 (0)2 37 26 09 99
Fax: +33 (0)2 37 26 09 98

Germany

Finienweg 3
28832 Achim/Bremen
Germany
Tel: +49 (0)4202 8852-0
Fax: +49 (0)4202 8852-25

Spain

Gaià 31, Pol. Ind. Plà d'en Coll
08110 Montcada i Reixac
Barcelona
Spain
Tel: +34 93 572 50 90
Fax: +34 93 572 50 91

Scandinavia

Tagenevägen 72
425 37 Hisings Kärra
Sweden
Tel: +46 31 57 51 00
Fax: +46 31 57 90 20

Genie United States

18340 NE 76th Street
P.O. Box 97030
Redmond, Washington 98073-9730
USA
Tel: +1 425 881-1800
Fax: +1 425 883-3475

WEB: www.genieindustries.com
Email: infoeurope@genieind.com

Distributed By: